



Please read and observe

these operating instructions carefully! Non-observation of the information it contains may lead to coupling malfunction or failure and consequential damage.

Danger and information symbols



Caution! Danger of personal injury and machine damage.



Note! Important points to observe.

Controlflex®

Controlflex® is a compact, electrically-insulating, precise shaft coupling with excellent kinematic properties. Modular construction makes it possible to realize all possible bore combinations from stock.

These installation and operating instructions are an integral part of your Controlflex®. They provide important information about correctly installation, operating and maintenance of your coupling.



Please read these instructions carefully and observe all notes.



The coupling must be installed only by qualified and trained personnel.



Controlflex® must be used only as outlined in the associated technical specifications.

Please read and observe

these operating instructions carefully! Non-observation of the information it contains may lead to coupling malfunction or failure and consequential damage.

Manufacturer's Declaration

This product is a component intended for installation in a plant or machine as defined by Machinery Safety Directive 98/37/EC. Commissioning must be performed only after the machine or plant in which this product is to be fitted has been confirmed as conforming to the requirements of the above EC Directive.

Safety instructions

These installation and operating instructions are an integral part of your Controlflex®. Always keep these instructions in an easily accessible place near the coupling.

They provide important information about correctly fitting, operating and maintaining your coupling.

Please read these instructions carefully and observe all notes. Controlflex® must be used only as outlined in the associated technical specifications.



Danger! Rotating drive components are potential for danger!

All persons working on or operating the machine or plant must observe the applicable safety regulations and instructions and take appropriate safety precautions. The machine's owner/operator is responsible for ensuring that all necessary safety precautions are in place and that the personnel has been appropriately instructed. The drive components must be used only for their intended purpose and within their specified technical operation limits.



Modifications

The product must not be reworked or otherwise modified.



The coupling must be installed only by qualified, trained personnel.



Carefully read these installation and operating instructions before fitting and commissioning the coupling.



The notes on safety contained in these instructions do not represent completeness.

Contents

Danger and information symbols	1
Manufacturer's Declaration	2
Safety instructions	2
Assembly of Controlflex®	3
Function	3
State of delivery	3
Parts list	3
Temperature stability	3
Maximum bore diameter	4
Misalignment capacity ratings	4
Installation	5
Maintenance	6
General notes	6

Assembly of Controlflex®

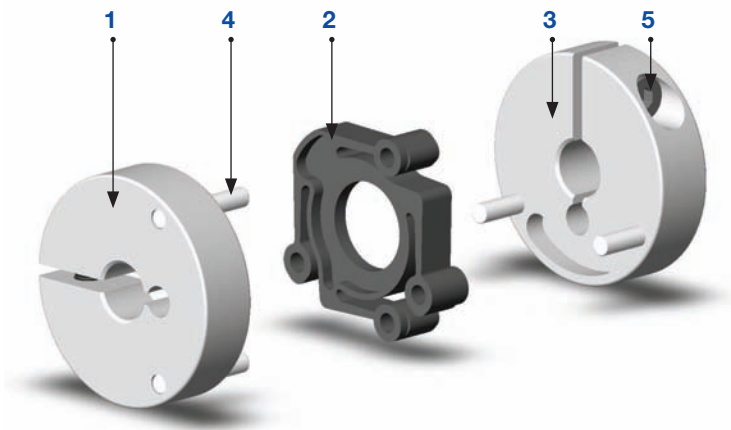

Parts list

- 1 Input clamp hub
- 2 Middle element
- 3 Output clamp hub
- 4 Pin
- 5 Clamp screw

Function

Controlflex® accommodates permanent shaft misalignments as well as shaft displacements occurring during operation. The smaller the misalignment at the time of installation, the greater is the coupling's compensation capability during operation. Keeping misalignment low also extends the couplings' lifespan and helps ensure quiet, smooth running. For the permissible misalignment ratings, see table of dimensions for your product. These values must not be exceeded during installation or operation (see table 2).

Controlflex® consists of two hard-coated aluminium clamp style hubs, each containing two press-fitted pins. The patented middle element that engages in the pins, provides the coupling with a large radial misalignment capacity. Rotational and swivelling movements are transmitted precisely with low restoring forces and with constant velocity even between shafts with a radial, axial and angular misalignment.

State of delivery

Controlflex® are supplied ready to install. The packaging is designed to prevent loss of the pre-fitted clamp screws. Although exceptionally rugged, Controlflex® should be protected from external forces. After the goods-in inspection, keep the couplings in their original packaging until they are ready to be fitted at their installation site.

 The product must not be reworked or otherwise modified. SCHMIDT-KUPPLUNG GmbH does not accept liability for any loss or damage resulting from such modifications.

Temperature stability

The couplings are suitable for continuous operation at temperatures from -30 °C to $+80\text{ °C}$. If operating temperatures are outside of this range, please consult the manufacturer.

Maximum bore diameter

Controlflex® are supplied ready to install with the desired bore diameter.



SCHMIDT-KUPPLUNG GmbH does not accept liability for any couplings with pre-bored hubs that have been reworked by the customer. The customer is solely responsible for any consequential loss, damage or injury in this case.



Caution!
The maximum bore diameter of Controlflex® (see table 1) must not be exceeded. Larger bores can result in destruction of the coupling. Coupling fragments hurled at high speed can cause serious or fatal injury.

Table 1: Maximum bore diameter (mm)

Model	Maximum bore diameter (mm)
Standard	
CPS 8.1	10
CPS 10.1	12
CPS 15.1	20
Impuls Plus	
CPS 8.2	10
CPS 10.2	12
CPS 15.2	20
Compact	
CPS 9.1	12
CPS 14.1	22
Industry	
CPS 23.1	30
CPS 30.1	40

Misalignment capacity ratings

The torsionally stiff Controlflex® accommodates radial, axial and angular shaft misalignments (see table 2).

The technical specifications and table 2 list the greatest permissible ratings for each kind of misalignment. The couplings reliably accommodate misalignments during operation, caused, for example, by thermal expansion or settling of the plant's foundations. Where several misalignment types occur at the same time, the maximum misalignment figures must be reduced. The sum of the actually occurring misalignments must not exceed 100 percent of the specified maximum value.

Table 2: Maximum misalignment ratings

Model	ΔK_r (mm)	ΔK_a (mm)	ΔK_w (°)
Standard			
CPS 8.1	0,4	0,3	1,5
CPS 10.1	1	0,5	1,5
CPS 15.1	1	0,7	1,5
Impuls Plus			
CPS 8.2	0,4	0,3	1
CPS 10.2	1	0,5	1
CPS 15.2	1	0,7	1
Compact			
CPS 9.1	1	0,5	1,5
CPS 14.1	1	0,7	1,5
Industry			
CPS 23.1	1,5	1	1,5
CPS 30.1	2	1,5	1,5

Installation

Observe the installation dimensions for your coupling model (see table 3). Controlflex® are normally assembled as complete units. If, instead, you fit the disassembled hubs to the shafts, make sure that the pins engage in the correct holes in the middle element. The shoulders of the middle element act as spacers and face the hub to be connected.

If a shaft protrudes beyond the face of the inner hub into the area of the middle element, make sure that the shaft diameter is smaller than the middle element's inner diameter minus by twice the maximum radial misalignment. The shaft ends to be joined and the bores of the hubs must be clean, dry and free from burrs. Check the tolerances and connection dimensions. The bores are supplied in tolerance F9.

Set the overall length according to table 3 or drawing and check after installation (in the delivery condition, the lower limit dimension is often used). Take into account the direction and magnitude of any length changes, for example of long shafts that are exposed to heat.

Tighten the clamp screws to the specified tightening torque (see table 4).

Table 3: Installation dimensions

Model	Overall length
Standard	
CPS 8.1	16
CPS 10.1	25,5
CPS 15.1	30
Impuls Plus	
CPS 8.2	20
CPS 10.2	31
CPS 15.2	38
Compact	
CPS 9.1	20,5
CPS 14.1	24
Industry	
CPS 23.1	45
CPS 30.1	57

Table 4: Screw tightening torques

Model	Screw size	Tightening torque (Nm)
Standard		
CPS 8.1	UNC 2-56x6	0,4
CPS 10.1	M3x12	1,3
CPS 15.1	M4x16	3
Impuls Plus		
CPS 8.2	UNC 2-56x6	0,4
CPS 10.2	M3x12	1,3
CPS 15.2	M4x16	3
Compact		
CPS 9.1	M2,5x12	0,7
CPS 14.1	M3x12	1,3
Industry		
CPS 23.1	M6x25	8
CPS 30.1	M8x30	24



Make sure the coupling does not accidentally come apart during dismounting. See section "Installation".

Maintenance

Controlflex® is maintenance-free.

To ensure the coupling's correct function, the patented middle element must be correctly fitted and has to be free from damage. Middle elements can be ordered as replacement kits.

SCHMIDT-KUPPLUNG GmbH does not accept liability for damage or injury caused by customer-serviced or modified couplings and/or couplings fitted with parts other than those supplied by SCHMIDT-KUPPLUNG. Any warranty becomes void through any such modifications.

General notes

The failure, incorrect selection and incorrect use of these products can lead to a faulty operation or failure of associated plant sections. Conversely, the incorrect functioning of connected components can cause these products to fail.

Our website, the technical brochures and other publications provide information to help you select the best suited product for your application. The suitability of the selected products should always be verified by a technical expert. Make sure that you have analyzed all aspects of your application and verified the product information provided in these publications.

Because of the many possible applications for these products and the wide range of operating conditions, the user of the products is exclusively responsible for ensuring that the selected products are suitable for the intended application and fulfil all applicable safety requirements. Where necessary, tests should be performed to ensure that the correct product has been selected.

The provided specifications are subject to change at any time without prior notification.

SCHMIDT-KUPPLUNG GmbH 2008